



SUMMER-2018 EXAMINATION

Subject Name: Advance Automobile Engine

Model Answer

17523

Important Instructions to examiners:

- 1) The answers should be examined by key words and not as word-to-word as given in the model answer scheme.
- 2) The model answer and the answer written by candidate may vary but the examiner may try to assess the understanding level of the candidate.
- 3) The language errors such as grammatical, spelling errors should not be given more Importance (Not applicable for subject English and Communication Skills).
- 4) While assessing figures, examiner may give credit for principal components indicated in the figure. The figures drawn by candidate and model answer may vary. The examiner may give credit for any equivalent figure drawn.
- 5) Credits may be given step wise for numerical problems. In some cases, the assumed constant values may vary and there may be some difference in the candidate's answers and model answer.
- 6) In case of some questions credit may be given by judgement on part of examiner of relevant answer based on candidate's understanding.
- 7) For programming language papers, credit may be given to any other program based on equivalent concept.

Q. No.	Sub Q. N.	Answer	Marking Scheme
1	A)	Attempt any THREE:	12
	a)	Define: i) Detonation ii) Pre-ignition.	4
		Answer: i) Detonation: - Detonation is auto-ignition of last part of homogeneous charge occurring near the end of combustion, before the flame front reaches it. In auto- ignition, the burning is almost instantaneous which results in extremely rapid release of energy causing pressure of the end gas to rise almost 3 to 4 times , from about 50 bar to 150 -200 bar. This large pressure differential gives rise to a severe pressure wave which strikes the cylinder wall and sets it vibrating, giving rise to a characteristic high pitched metallic ringing sound as if stroke struck by light hammer. ii) Pre-ignition:- Pre-ignition is the ignition of the homogeneous mixture in the cylinder, before the timed ignition spark occurs, caused by the local overheating of the combustible mixture. Pre ignition is initiated by some overheated projecting part such as the sparking plug electrodes, exhaust valve head, metal corners in the combustion chamber, carbon deposits etc.	2 2
	b)	List two drawbacks of carbureted SI engine during fuel distribution and drivability.	4
		Answer: (any two from each) Fuel distribution : Drawbacks 1. Mal-distribution of charge. 2. Inaccurate metering of charge. 3. Fuel atomization depends upon velocity of air in the venture.	2



Drivability: Drawbacks

- 1) Variation in air: fuel ratio.
- 2) Does not meet emission norms.
- 3) No temperature compensation.
- 4) No compensation of Exhaust gas recirculation.
- 5) Backfiring may take place.

2

c) **Differentiate air fuel ratio between carburetted engine and electronic fuel injection engines control system.**

4

Answer:- (Any 4 points- 1 marks for each point)

Sr. No.	Carburetted engine	Electronic Fuel Injection (EFI) engine
1	Fuel atomization depends upon velocity of air in the venturi.	Atomization of fuel is independent of cranking speed therefore cranking is easier.
2	Less atomization and vaporization will make the engine more knock prone.	Better atomization and vaporization will make the engine less knock prone.
3	Amount of fuel added is done by float chamber, needle valve and venturi pressure.	Amount of fuel added can be adjusted by changing the injector plus width or by increasing fuel pressure
4	Amount of air entering is depends on opening and closing of throttle valve	Amount of air entering is measured by Mass Air Flow sensor and controlled by ECU.
5	Wall wetting effect occurs in carbureted engine.	Equal quantity of fuel is supplied to port for each cylinder

4

d) **Write the values of boiling temperature for cetane(diesel).iso-octane(petrol), Butane, Propane an methane fuel and write effect of it on its system.**

4

Answer:

Sr. No.	Type of fuel	Boiling temperature	Effects on system
1	Cetane(diesel)	180 - 360 °C	System requires More Combustion pressure and temperature to burn.
2	Isooctane(petrol)	95 - 99.2 °C	System Require less temperature and pressure to burn
3	Butane	-1 to 1 °C	In the form of Liquefied petroleum gas.
4	Propane	-42.25 to 42.04 °C	1. System requires more or less oxygen for complete combustion. 2. No Need of carburetor or other vaporizing device is require to vaporize.
5	Methane	-161.50 °C	In the form of Compressed natural gas.

4

B)	Attempt any ONE:	6
a)	Draw neat sketch to show TBI system of SI engine and name its parts.	6
	<p>Answer: (Sketch 4 marks, labeling 2 marks, credit should be given to equivalent figure)</p> <div style="display: flex; justify-content: space-around; align-items: center;"> <div data-bbox="219 546 738 934"> <p>Fig. Throttle Body Injection (Single Point)</p> </div> <div data-bbox="787 357 1429 987"> <p>Engine</p> </div> </div> <p style="text-align: center;">OR</p> <p style="text-align: center;">Fig. Throttle Body Injection System(TBI)</p>	6
b)	Draw block diagram for CRDI engines and name the parts.	6
	<p>Answer: (Block diagram:- 4 marks, Parts name:-2 marks) Block diagram CRDI engine</p> <p style="text-align: center;">Other Sensors</p> <ul style="list-style-type: none"> -Reference mark, Engine speed -Accelerator pedal position, Loading pressure -Radiator and air temperature sensor 	6

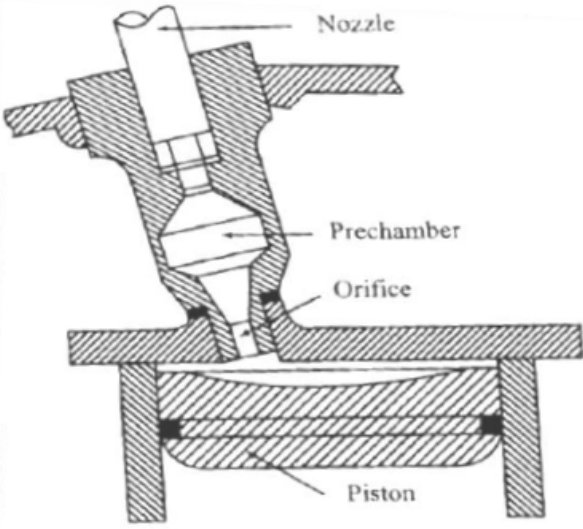

		<p>OR</p> <div style="border: 1px solid black; padding: 10px; margin: 0 auto; width: 80%;"> <table style="width: 100%; border-collapse: collapse;"> <tr> <td style="width: 33%; border-right: 1px solid black; padding: 5px;"> <p style="text-align: center; margin: 0;">SENSORS</p> <p>Coolant Temp. ➔</p> <p>Air Temperature ➔</p> <p>Boost Pressure ➔</p> <p>Engine Speed ➔</p> <p>Vehicle Speed ➔</p> <p>Fuel Quantity ➔</p> <p>Injection Begin ➔</p> <hr style="border: 0.5px solid black;"/> <p>Setpoint Generators</p> <p>Accelerator Sensor ➔</p> <p>Speed Selection Lever ➔</p> </td> <td style="width: 33%; border-right: 1px solid black; padding: 5px; text-align: center;"> <p>ECU</p> <p>Fuel Quantity</p> <p>Engine Shut Off</p> <p>Injection Begins</p> <p>Starting Control</p> <p style="writing-mode: vertical-rl; transform: rotate(180deg);">Micro processor</p> <div style="border: 1px solid black; width: 100%; height: 15px; margin: 5px auto;"></div> <p>MAPS (Database)</p> <p style="text-align: center;">↑</p> </td> <td style="width: 33%; padding: 5px;"> <p style="text-align: center;">Actuators</p> <div style="border: 1px solid black; padding: 5px; margin: 5px auto; width: 80%;"> <p style="text-align: center;">Fuel Injection Pump</p> </div> <p style="margin-top: 10px;">➔</p> <p style="margin-top: 10px;">➔</p> <p style="margin-top: 10px;">➔</p> <p style="margin-top: 10px;">➔</p> <hr style="border: 0.5px solid black;"/> <p>Diagnosis</p> <p>Diagnostic Display</p> </td> </tr> </table> </div>	<p style="text-align: center; margin: 0;">SENSORS</p> <p>Coolant Temp. ➔</p> <p>Air Temperature ➔</p> <p>Boost Pressure ➔</p> <p>Engine Speed ➔</p> <p>Vehicle Speed ➔</p> <p>Fuel Quantity ➔</p> <p>Injection Begin ➔</p> <hr style="border: 0.5px solid black;"/> <p>Setpoint Generators</p> <p>Accelerator Sensor ➔</p> <p>Speed Selection Lever ➔</p>	<p>ECU</p> <p>Fuel Quantity</p> <p>Engine Shut Off</p> <p>Injection Begins</p> <p>Starting Control</p> <p style="writing-mode: vertical-rl; transform: rotate(180deg);">Micro processor</p> <div style="border: 1px solid black; width: 100%; height: 15px; margin: 5px auto;"></div> <p>MAPS (Database)</p> <p style="text-align: center;">↑</p>	<p style="text-align: center;">Actuators</p> <div style="border: 1px solid black; padding: 5px; margin: 5px auto; width: 80%;"> <p style="text-align: center;">Fuel Injection Pump</p> </div> <p style="margin-top: 10px;">➔</p> <p style="margin-top: 10px;">➔</p> <p style="margin-top: 10px;">➔</p> <p style="margin-top: 10px;">➔</p> <hr style="border: 0.5px solid black;"/> <p>Diagnosis</p> <p>Diagnostic Display</p>	
<p style="text-align: center; margin: 0;">SENSORS</p> <p>Coolant Temp. ➔</p> <p>Air Temperature ➔</p> <p>Boost Pressure ➔</p> <p>Engine Speed ➔</p> <p>Vehicle Speed ➔</p> <p>Fuel Quantity ➔</p> <p>Injection Begin ➔</p> <hr style="border: 0.5px solid black;"/> <p>Setpoint Generators</p> <p>Accelerator Sensor ➔</p> <p>Speed Selection Lever ➔</p>	<p>ECU</p> <p>Fuel Quantity</p> <p>Engine Shut Off</p> <p>Injection Begins</p> <p>Starting Control</p> <p style="writing-mode: vertical-rl; transform: rotate(180deg);">Micro processor</p> <div style="border: 1px solid black; width: 100%; height: 15px; margin: 5px auto;"></div> <p>MAPS (Database)</p> <p style="text-align: center;">↑</p>	<p style="text-align: center;">Actuators</p> <div style="border: 1px solid black; padding: 5px; margin: 5px auto; width: 80%;"> <p style="text-align: center;">Fuel Injection Pump</p> </div> <p style="margin-top: 10px;">➔</p> <p style="margin-top: 10px;">➔</p> <p style="margin-top: 10px;">➔</p> <p style="margin-top: 10px;">➔</p> <hr style="border: 0.5px solid black;"/> <p>Diagnosis</p> <p>Diagnostic Display</p>				
2		Attempt any FOUR:	16			
	a)	List down the effect of detonation on S I engine.	4			
		<p>Answer: (Any 4 - 1 mark each)</p> <ol style="list-style-type: none"> 1. Noise and roughness: Mild knock is seldom audible and is not harmful. When intensity of knock increases a loud pulsating noise is produced due to development of a pressure wave. The presence of vibratory motion causes crankshaft vibrations and engines rough. 2. Mechanical damage: Due to rapid pressure waves, rate of wear is increased and piston head, cylinder head and valves may be pitted. 3. Carbon deposits: Detonation results in increased carbon deposits. 4. Increase in heat transfer: Temperature in detonating engine is higher as compared to non-detonating engine and hence scoring away the protecting layer of inactive stagnant gas. So detonation increases the rate of heat transfer to combustion chamber walls. 5. Decrease in power output and efficiency: Due to increase in the rate of heat transfer the power output is decreased. 6. Pre ignition: Detonation results in over heating of the sparking plug and combustion chamber wall and this overheating leads to ignite the charge before the passage of spark 	4			
	b)	Why pressure regulator is required in fuel supply system of EFI system engine?	4			
		<p>Answer:</p> <ol style="list-style-type: none"> 1. In low pressure common rail systems (EFI) that do not require high capacity fuel flow where the fuel injector is mounted on a intake manifold port runner on engine displacing less than 2.0 liters. Fuel pressure require less than 30 psi at maximum duty (cycle) fuel flow per injector cycle to maintain this requirements pressure regulator is used. 2. Pressure regulator is used to relieve pressure if abnormally high system pressure is generated inside the EFI system. 3. The pressure regulator keeps the pressure drop across the injector fuel line and the intake manifold as constant. 	4			

	<p>4. The fuel pump provides more fuel than the maximum required by the engine. Fuel not used by the engine is returned to the fuel tank by using pressure regulator.</p> <p>5. The diaphragm operated a valve which opens at a differential pressure between 2.0 and 3.5 bar and allows excess fuel to return to the fuel tank.</p>	
c)	What is meant by surface ignition in SI engine?	4
	<p>Answer: Surface ignition: Surface ignition is the ignition of the fuel-air mixture by a hot spot on the combustion chamber walls such as on overheated valve or spark plug or glowing combustion Chamber i.e. any means other than the normal spark discharge. Due to surface ignition a turbulent flame develop at each surface ignition locations and start propagates across the chamber in an analogous manner to what occurs in normal knock.</p>	4
d)	Name the sensors which are placed at intake manifold ,throttle valve, water jacket and exhaust manifold.	4
	<p>Answer: (1 marks for each) Sensors: Intake manifolds:- Mass air flow sensor (MAF), Manifold absolute pressure sensor (MAP) Throttle valve:- Throttle position sensor (TPS) Water jacket:- Engine temperature sensor or coolant temperature sensor Exhaust manifolds: - Exhaust gas temperature sensor, Oxygen sensor (O₂)</p>	
e)	Draw neat sketch of pre-combustion chamber and name its parts.	4
	<p>Answer:(sketch:- 3 marks, name:- 1 mark)</p> <div style="text-align: center;">  </div> <p style="text-align: center;">Fig. Pre-combustion chamber (credit should be give suitable sketch)</p>	4



f)	Describe air fuel- ratio requirements for diesel engines at no load to full load.	4									
	<p>Answer: (Credit should be given to an equivalent answer) Irrespective of load at any given speed, an approximately constant supply of air enters the cylinder. With change in load, the quantity of fuel injected is changed varying the air fuel ratio.</p> <p>The overall air fuel ratio thus varies from about 18:1 at full load to about 80:1 at no load. The diesel engine always designed to operate with an excess air of 15 to 40% depending upon the application</p>	4									
3	Attempt any FOUR:	16									
	a) Compare SI and CI engine on the basis of compression ratio and supercharging.	4									
	<p>Answer:(Each difference 2 marks)</p> <table border="1" style="width: 100%; border-collapse: collapse;"> <thead> <tr> <th style="width: 25%;">Parameter</th> <th style="width: 35%;">SI engine</th> <th style="width: 40%;">CI engine</th> </tr> </thead> <tbody> <tr> <td>Compression ratio</td> <td>Compression ratio is low, about 10:1 limited by detonation</td> <td>Compression ratio is higher, about 18:1 to 22:1</td> </tr> <tr> <td>Supercharging</td> <td>Limited by detonation ,used only in air craft engines</td> <td>Inherently suitable, widely used. Limited by blower power and mechanical And thermal stresses</td> </tr> </tbody> </table>	Parameter	SI engine	CI engine	Compression ratio	Compression ratio is low, about 10:1 limited by detonation	Compression ratio is higher, about 18:1 to 22:1	Supercharging	Limited by detonation ,used only in air craft engines	Inherently suitable, widely used. Limited by blower power and mechanical And thermal stresses	
Parameter	SI engine	CI engine									
Compression ratio	Compression ratio is low, about 10:1 limited by detonation	Compression ratio is higher, about 18:1 to 22:1									
Supercharging	Limited by detonation ,used only in air craft engines	Inherently suitable, widely used. Limited by blower power and mechanical And thermal stresses									
	b) Write the function of Canister purge and EGR.	4									
	<p>Function of Canister purge: Activated charcoal can store petrol vapours until the right time for them to be drawn into the engine and burnt. When the engine is off, vapours are routed through lines and hoses to a charcoal canister where they are stored. When the engine is running, the vapours are purged from the canister. They are drawn to the intake manifold for burning in the cylinders.</p> <p>Function of EGR: To reduce the amount of NO_x in the exhaust. The EGR system re-circulates exhaust gases through the intake manifold in order to reduce the temperature at which combustion takes place. The EGR system allows a small amount of exhaust gas (less than 10% of total) to be supplied into the incoming air: fuel mixture.</p>	2 2									
	c) Why fuel does not explode even though fuel pump is fitted in the fuel tank itself.	4									
	<p>Answer: For the combustion/explosion to take place appropriate air fuel mixture and a source of ignition i.e. spark is required. The electric fuel pump is placed inside the fuel tank and is immersed in the fuel, Since there is no contact of air; No oxygen is available for it to burn i.e. appropriate air fuel mixture is not available. So fuel does not explode even though fuel pump is filled in the fuel tank itself.</p>	4									
	d) Write the function of high pressure accumulator.	4									
	<p>Answer: (Each Function 1Marks) High pressure accumulator: The function of high pressure accumulator is to 1.Accumulate fuel supplied by the high pressure fuel pump</p>	4									

2. Supply fuel through the high pressure lines to the individual injectors.
3. It also dampens the fuel pressure fluctuation caused by high pressure pulses.
4. To allow excess fuel to pass through fuel regulator when pressure increases above specified value.

e) Draw block diagram for EDC type fuel pump in diesel engine.

4

Answer: Block diagram for EDC type fuel pump in diesel engine

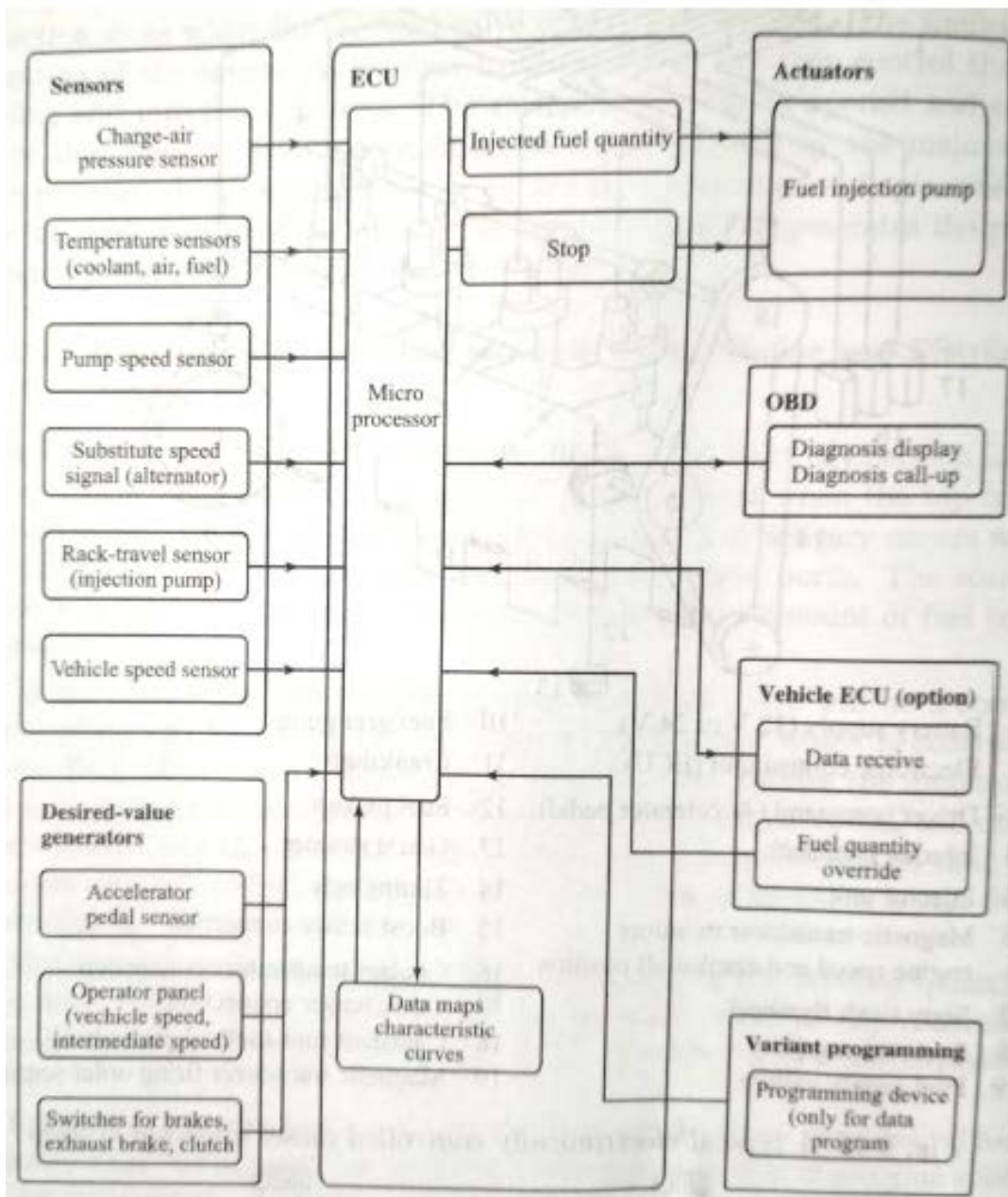

4

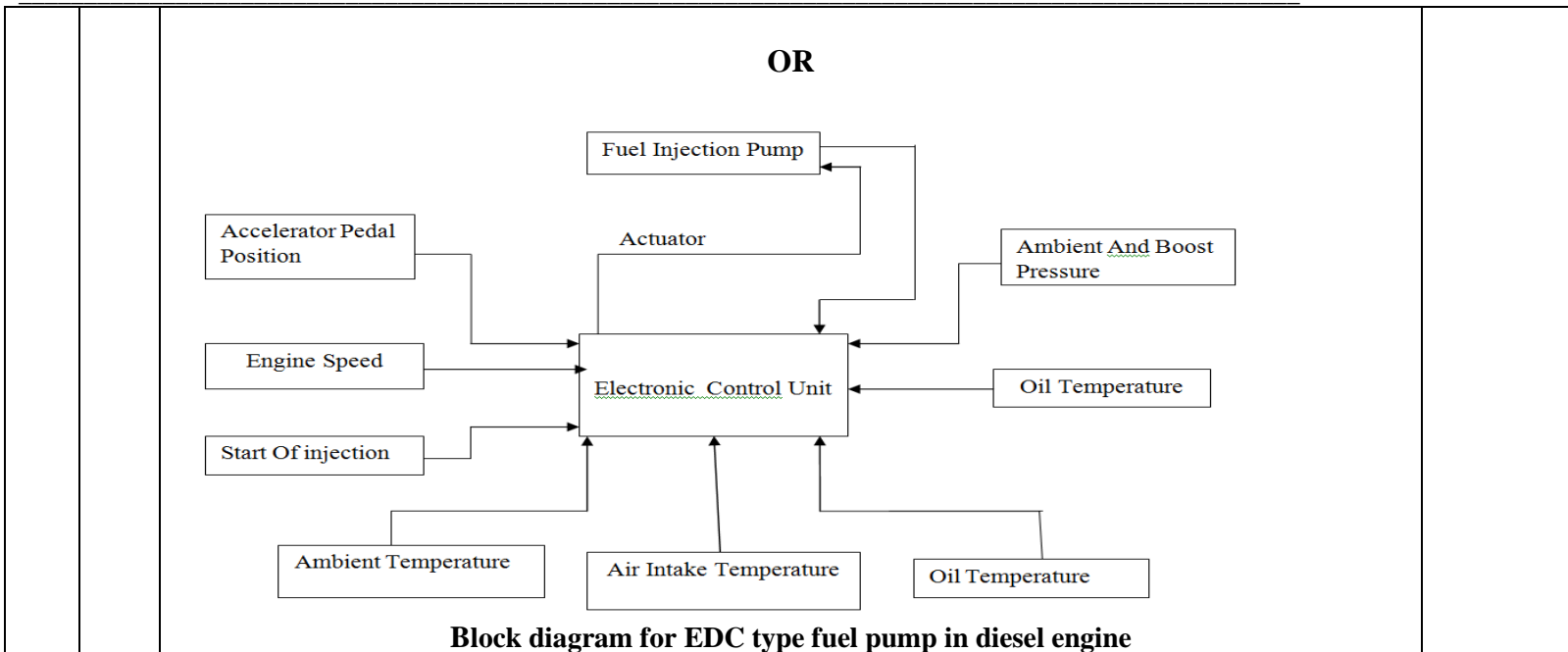

f) Draw circuit diagram for diesel engine Glow plug. 4

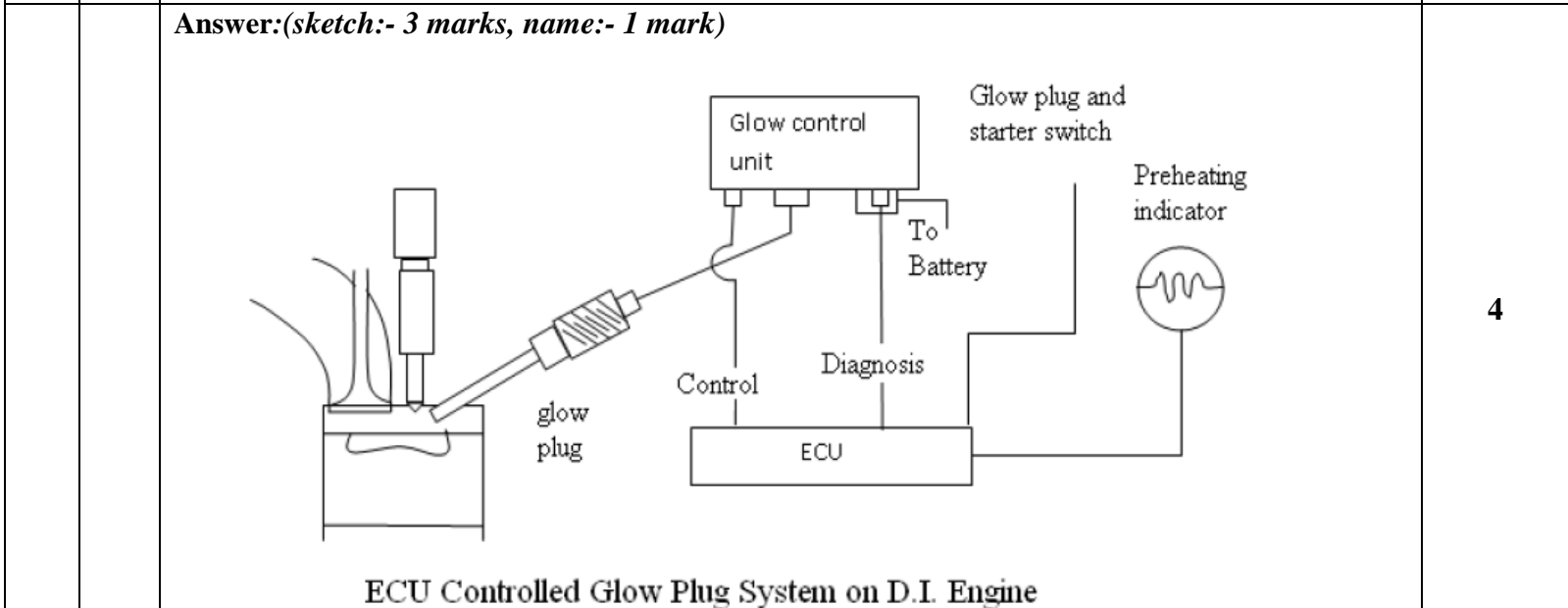

4 A) Attempt any THREE: 12

a) Write the difference between LPG & CNG with respect to its calorific value, Compression ratio, air fuel ratio and octane rating 4

Answer:(Each difference, 1 marks)

Parameter	LPG	CNG
Calorific value	46.1MJ/Kg or 3.39MJ/ cu.m	49 MJ/Kg
Compression ratio	17:1	10:1 to 11:1
Air fuel ratio	Stichomythic air fuel ratio By mass:15.5:1 By volume:23.9:1	Stichomythic air fuel ratio By mass:17.2:1 By volume:9.7:1
Octane rating	111	130

4



b)	Draw block diagram of LPG fuel supply system.	4
	<p>Answer:</p> <pre>graph TD; A[External Filler Valve] --> B[LPG Tank]; B --> C[Gas Shut-off valve]; C --> D[Evaporator pressure regulator]; D --> E[LPG injectors at Intake port]; E --> F[I.C. engine combustion chamber]; G[Filtered air to Throttle device] --> H[Intake manifold Pressure Sensor]; H --> E; C --- I[Petrol / Gas Switch]; C --- J[LPG - Electronic control Unit]; D --- K[CAN interface]; E --- L[Diagnostic Lamp]; E --- M[Diagnostic Interface];</pre>	4
c)	Explain Biodiesel fuel. Give any four applications.	4
	<p>Answer: (Explanation 2 Marks, Two Applications 2 marks)</p> <p>Biodiesel diesel</p> <p>Bio diesel is a vegetable oil or animal fat based diesel fuel. It consists of long chain alkyl esters. It is made chemically reacting liquids with an alcohol.</p> <ul style="list-style-type: none">i) It is a renewable substitute fuel for petroleum diesel.ii) It has lower exhaust emissionsiii) It is biodegradable fueliv) It is non-toxic.v) It is free of sulphur and aromatics.vi) It is an environmentally friendly fuel that can be used in any diesel engine without modification. <p>Applications</p> <ul style="list-style-type: none">1. Diesel Engines2. Common rail direct injection diesel engines3. Railway engines with blend(80% Petro diesel with 20% biodiesel)4. Generatore5. Air craft engines6. Heating oil in domestic commercial boiler	2



d)	State the difference between turbocharger & VGT used in diesel engine.			4
	Answer Difference between turbocharger and VGT (Any 4 points-1mark each)			4
Sr. No.	Parameter	Turbocharger	VGT	
1	Fuel efficiency	Lower fuel efficiency as compared to VGT	Improved fuel efficiency by 20%	
2	Turbo-lag	More Turbo-lag	Reduced Turbo-lag	
3	Power output	Lower power output at lower speeds	Higher power output even at lower speeds	
4	Boost pressure at low speed	Low	Adequate	
5	Boost pressure at high speeds	Increased boost pressure, requires waste gate boost control	It is not excessive so waste gate boost control is not required.	
6	Engine response	Sluggish response at low speeds	Quick responsive engine	
B)	Attempt any ONE:			6
a)	List any four advantages of CRDI system and write its operation.			6
	<p>Answer:(Any 4 advantages, 4 marks, Operation, 2 marks)</p> <p>Advantages of CRDI System:</p> <ol style="list-style-type: none"> 1. Deliver 25% more power and torque than the normal direct injection engine. 2. Lower levels of noise and vibration. 3. Lower emissions. 4. Lower fuel consumption. 5. Improved performance. 6. Improved drivability <p>Operation of CRDI system:</p> <p>High pressure pump provides high pressure fuel to the common rail. The common rail stores the fuel and maintains a constant pressure in the common rail line (approximately 1500 bars.). This pressure is continuously available at injectors.</p> <p>The injection pressure is independent of engine speed. The quantity of fuel injected in the combustion chamber is controlled by actuating solenoid valve in the injector. As solenoid is energized, injection begins. Injector pulse width, multiple injections and duration of injection – all are controlled by EDC of CRDI system.</p> <p>The system pressure is controlled by means of a pressure sensor. Pilot injection and possibly a second, third injection is achieved by repeatedly activating solenoid valve, whereas the injection rate can be modified by controlling the nozzle needle movement.</p>			
b)	Write about need advantages and of limitation in Hybrid vehicles.			6
	<p>Answer:(Need 2 marks ,advantages, 2 marks, Limitations, 2 marks)</p> <p>Need of Hybrid Vehicle</p> <ol style="list-style-type: none"> 1. To increase fuel efficiency. 2. To reduce gaseous emission. 3. To increase acceleration capability. 4. To reduce noise emission. 5. To reduce fuel consumption 			2

Advantages

1. Environment friendly.
2. Financial benefits.
3. Less dependent on fissile fuels.
4. Regenerative braking system.
5. Built from light materials.

2

Limitations.

1. Less power.
2. Can be expensive.
3. Poorer handling.
4. Higher maintenance cost.

2

5

Attempt any TWO:

16

a) **Draw P-Q diagram for stages of combustion in SI engine and write stages of combustion with its explanation.**

8

Answer:- (sketch:- 4 marks, explanation:- 4 marks)

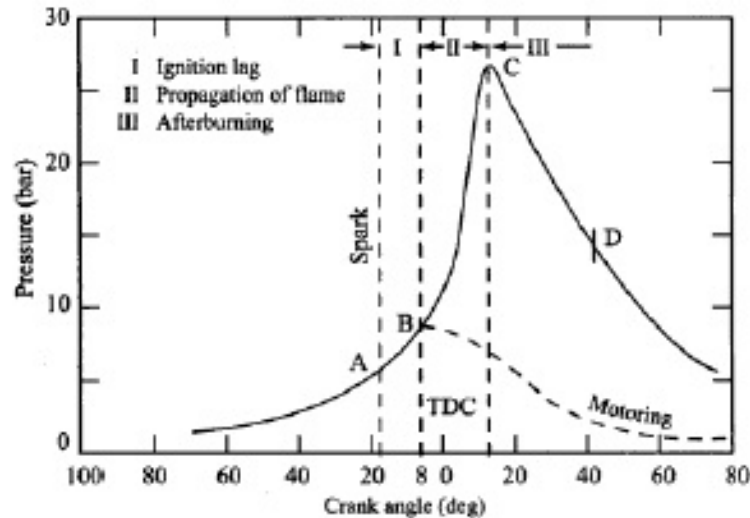

Fig. Stages of combustion in S I engine.

The stages of combustion in S.I. engine:

8

Stage I: Ignition Lag or Preparation Phase:

It is a chemical process which depends on-nature of fuel, temperature & pressure, proportion of exhaust gas, rate of burning and temperature .It is the growth and development of a semi propagating nucleus of flame.(At the moment of spark discharge, the temperature exceeds 10,000°C)

- i. At the end of this stage, the first rise of pressure (on indicator diagram) can be detected. It is the point where the line of combustion departs from the compression line.
- ii. The start of first stage is ignition of charge (a sufficiently homogeneous mixture of vaporized fuel, air & residual gases), leaving behind a thin thread of the flame. From this thin thread combustion spreads to envelop of mixture immediately surrounding it.

Stage II: Propagation of flame:

It is a simple, pure and mechanical process. The starting point of the second stage is where first measurable rise of pressure can be seen on the indicator diagram. i.e. the point where the line of the combustion departs from the compression line. During second stage, the flame spreads

throughout the combustion chamber. The second stage ends as maximum pressure (on indicator diagram) is reached.

Stage III: After burning.

End of second stage means completion of flame travel. But it does not result in complete heat release (burning of fuel). Even after the passage of flame, some chemical adjustments continue throughout the expansion stroke- near the walls and behind the turbulent flame front. The rate of combustion reduces due to surface of the flame front becoming smaller and reduction in turbulence.

b) Compare sequential, continuous grouped and simultaneous methods of fuel injection.

8

Answer:- (Each method:- 2 mark)

Sequential fuel injection (SFI):-Injection of fuel occurs at the same time for all cylinders every revolution of the crankshaft. Therefore, fuel is injected twice within each four-stroke cycle. The injection timing is fixed with respect to crank/ cam shaft position.

Continuous injection:-This system usually has a rotary pump. The pump maintains a fuel line gauge pressure of about 0.75 to 1.5 bar. The system injects the fuel through a nozzle located in manifold Immediately downstream of the throttle plate. In supercharged engine, fuel is injected at the entrance of the supercharger. The timing and duration of the fuel injection is determined by ECU depending upon load and speed

Grouped fuel injection:-The injectors are divided into two groups that are controlled separately. Each group injects once per four-stroke cycle. The offset between the groups is one crankshaft revolution. This arrangement allows.

Simultaneous Injection: Injection of fuel occurs at the same time for all cylinders every revolution of the crankshaft. Therefore, fuel is injected twice within each four-stroke cycle. The injection timing is fixed with respect to crank/ cam shaft position.

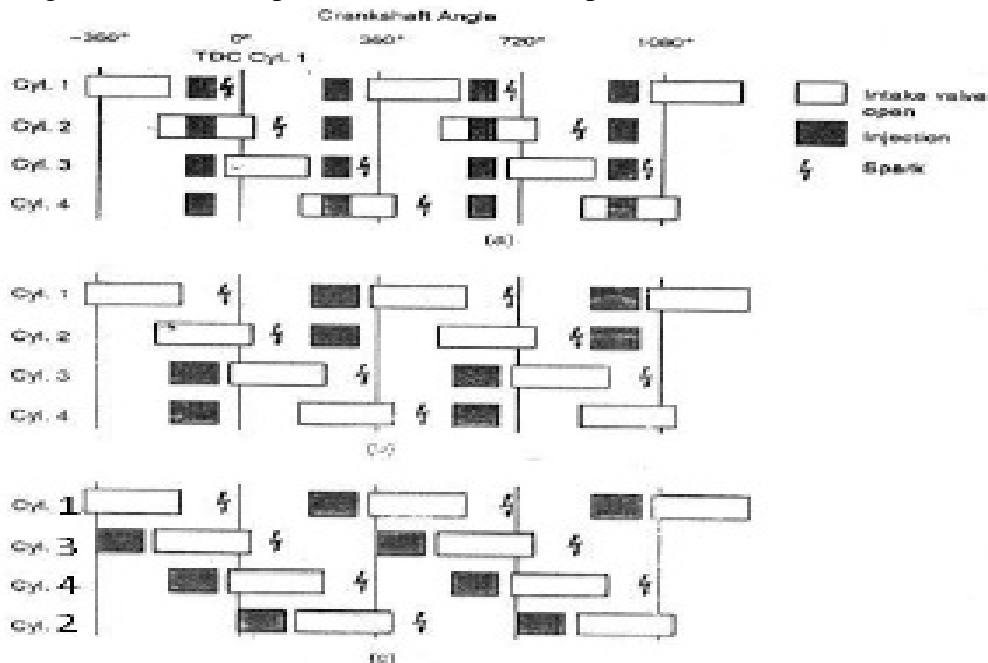

8

Fig. fuel injection stages:- 1)simultaneous injection 2) Group Injection 3) Sequential injection
Note: Above diagram refers to the first three methods of injection, for continuous injection diagram is not needed)



c)	How gasoline engine emission is controlled by engine design modification and treatment of exhaust gas?	8
	<p>Answer: (Methods:- 4 marks, exhaust gas treatment:- 4 marks)</p> <p>Methods used for controlling of gasoline engine emission by engine design modification are:-</p> <ol style="list-style-type: none">1. Use of leaner air-fuel ratios: The carburetor may be modified to provide relatively lean air fuel mixtures during idling and cruise operation. With this modification, idle speed needs to be increased to prevent stalling and rough idle. Fuel distribution is improved by better manifold design, Inlet air heating, raising of coolant temperature and use of electronic fuel injection system.2. Retarding Ignition timing: The controls are designed to retard the spark timing at idle and providing normal spark advance during acceleration and cruising. Retarding spark reduces NOX. Emission. It also reduces HC emission.3. Modification of combustion chamber: Modification in combustion chamber is attempted to avoid flame quenching zones, resulting in HC emission. This includes reducing surface to volume ratio, reduced squish area, reduced deal space around piston ring and reduced distance of the top piston ring from the top of the piston.4. Lower compression ratio: The lower compression ratio reduces the quenching effect by reducing quenching area reducing HC. It also reduces NOX. Emission. Reducing compression ratio results in some loss of power and fuel economy.5. Reduced valve overlap: Increased valve overlap allows some mixture to escape directly to increase emission level. This can be controlled by reducing valve overlap.6. Alterations in induction system: The supply of designed air fuel ratio to all cylinders under all operating conditions can be affected by alterations in induction. This includes inlet air heating, use of carburetor with closer tolerances and using special type of carburetors. This also includes fuel injection in manifold. <p>Treatment of exhaust gas:-</p> <p>Catalytic converter Catalytic converter is used in a vehicle (exhaust system) to convert undesirable exhaust gases into harmless gases. As part of the exhaust system, it also helps reduce the noise level of the exhaust. The three-way or selective catalytic converter with lambda closed-loop control has proven to be an effective concept for exhaust –gas after treatment. It is capable of providing the required reduction of all three pollutants (NOx, CO and HC) The converter if operated at temperature of approx. 400...800°C, provided the engine is operated with a nearly stoichiometric mixture ($\lambda= 0.99$ to 1.) gives maximum conversion efficiency and extended Service life.</p> <p>Exhaust Gas Recirculation:- EGR System control by the ECM. A pressure sensor monitors the exhaust system pressure. The sensor signals this information to the ECM. The ECM sends the signal to electronic vacuum regulator valve (EVR) to open and close the EGR valve. Thus it controls the amount of exhaust gas recalculated.</p>	8



6		Attempt any FOUR:	16
	a)	Explain VVT mechanism and state any two advantages of it.	4
		<p>Answer: (Explain:- 2 marks, advantages:- 2 marks) Variable valve timing (VVT) is a system for varying the valve opening of an internal combustion engine. This allows the engine to deliver high power, but also to work tractably and efficiently at low power. There are many systems for VVT, which involve changing either the relative timing, duration or opening of the engine's inlet and exhaust valves.</p> <p>Cam changing VVT: Stage 1 (low speed): the 3 pieces of rocker arms moves independently. Therefore the left rocker arm, which actuates the left inlet valve, is driven by the low-lift left cam. The right rocker arm, which actuates the right inlet valve, is driven by the medium-lift right cam. Both cams' timing is relatively slow compare with the middle cam, which actuates no valve now. Stage 2 (medium speed): hydraulic pressure (painted orange in the picture) connects the left and right rocker arms together, leaving the middle rocker arm and cam to run on their own. Since the right cam is larger than the left cam, those connected rocker arms are actually driven by the right cam. As a result, both inlet valves obtain slow timing but medium lift. Stage 3 (high speed): hydraulic pressure connects all 3 rocker arms together. Since the middle cam is the largest, both inlet valves are actually driven by that fast cam. Therefore, fast timing and high lift are obtained in both valves</p> <p>Advantages of VVT (Any two)</p> <ol style="list-style-type: none">1) It improves performance of an engine.2) It increases engine flexibility under different conditions.3) It improves fuel economy.4) It makes precise handling of engine valve.5) It lowers the exhaust emission.6) It increases torque.	4
	b)	List any four parameters of improving fuel economy.	4
		<p>Answer: (Any four :-1 mark for each)</p> <ol style="list-style-type: none">1. Use of multi-functional fuel additives will provide 3 to 4% fuel economy.2. Good driving habits.3. Properly maintained fuel supply system.4. Use of computer controlled fuel injection system.5. Use of computer controlled ignition system.6. Use of higher voltage automotive electrical system (42 volts system).	4
	c)	List down the pollutants from gasoline engine and diesel engine.	4
		<p>Answer:- (1/2 marks for each pollutants) Pollutants from gasoline engine:-</p> <ol style="list-style-type: none">1. Hydrocarbons.2. Carbon Monoxide.3. Carbon dioxide.4. Oxides of Nitrogen.5.	2

Pollutants from diesel engine:-

1. Hydrocarbons
2. Carbon Monoxide.
3. Carbon dioxide.
4. Oxides of Nitrogen.
5. Particulate matters.

2

d) List out the methods for evaporation control and explain any one.

4

Answer:- (List: 1 marks, explain:- 3 marks)

Methods for evaporation control:-

1. Charcoal Canister System (for Fuel tank and carburetor float bowl emissions)
2. Positive Crankcase Ventilation (PCV) System (for crankcase emissions)

1

1. Charcoal Canister System (for Fuel tank and carburetor float bowl emissions)

When the engine is running, stored fuel vapours in fuel tank are purged from the canister whenever the throttle has opened past the purge port and coolant temperature is above 54 °C. Fuel vapours flow from the high pressure area in the canister, past check valve in the canister, through the vacuum switching valve (ECM controlled- duty cycle controlled), to the low pressure area in the throttle body. ECM uses engine speed, intake air volume, coolant temperature, and oxygen sensor information to control EVAP operation. Atmospheric pressure is allowed into the canister through a filter located on the bottom of the canister. This ensures that the purge flow is constantly maintained whenever purge vacuum is applied to the canister. When coolant temperature falls below 35°C, the vacuum switching valve prevents purge from taking place by blocking the vacuum signal to the check valve at canister. Under other conditions, as fuel is drawn from the tank, a vacuum may be created in the tank. This is prevented by allowing atmospheric pressure to enter the tank through the check valve in the charcoal canister or fuel tank cap check valve. The EVAP system is designed to limit maximum vacuum and pressure in the fuel tank.

3

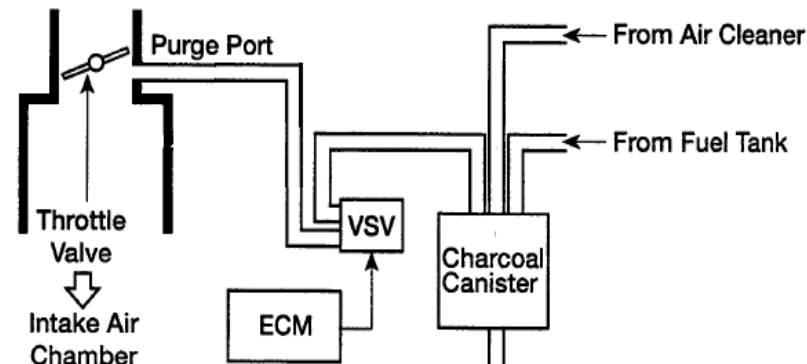

VSV: Vacuum Switching Valve ECM: Electronic Control Module

Fig. Evaporative emission system(Charcoal Canister)

Note: Equivalent credit shall be given to any other suitable diagram.

OR

2. Positive Crankcase Ventilation (PCV) System (for crankcase emissions)

During normal compression stroke, a small amount of gases in the combustion chamber escapes past the piston. Approximately 70 % of these 'blow-by' gases are unburned fuel (HC) that can dilute and contaminate the engine oil, cause corrosion to critical parts, and contribute to sludge build up. At higher engine speeds, blow-by gases increase crankcase pressure that can cause oil leakage from sealed engine surfaces. The purpose of PCV system is to remove these harmful gases from the crankcase before damage occurs and combine them with the engine's normal incoming air: fuel mixture. PCV system uses a variable flow PCV valve accurately matches ventilation flow with blow-by production characteristics. By accurately matching these two factors, crankcase ventilation performance is optimized, while engine performance and drivability remains unaffected.

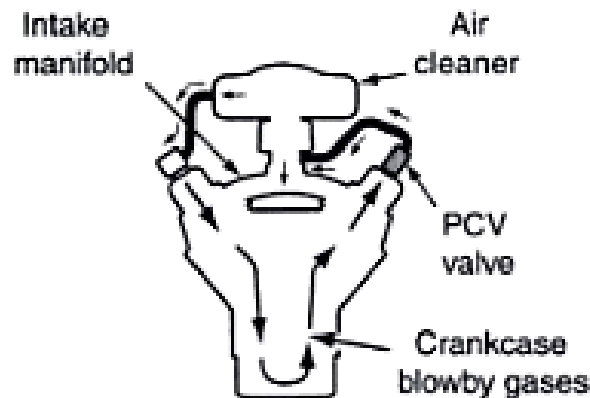

Figure: Positive Crankcase Ventilation System

3

e) Write Bharat stage norms for the car which is manufactured in 2016

4

Answer:- Bharat stage norms for the car (Credit should be given to information in sentence format, mentioning Bharat stage norms being equivalent to corresponding Euro norms. Two / three rows need to be appearing for BS and Euro emission norms containing permissible levels of pollutants)



Indian emission standards (4-wheel vehicles)

Standard	Reference	Date	Region
India 2000	Euro 1	2000	Nationwide
Bharat Stage II	Euro 2	2001	NCR*, Mumbai, Kolkata, Chennai
		2003.04	NCR*, 11 cities†
		2005.04	Nationwide
Bharat Stage III	Euro 3	2005.04	NCR*, 11 cities†
		2010.04	Nationwide
Bharat Stage IV	Euro 4	2010.04	NCR*, 13 cities‡
		2015.07	Above plus 29 cities mainly in the states of Haryana, Uttar Pradesh, Rajasthan and Maharashtra [3231]
		2015.10	North India plus bordering districts of Rajasthan (9 States) [3232]
		2016.04	Western India plus parts of South and East India (10 States and Territories) [3232]
		2017.04	Nationwide [3232]
Bharat Stage V	Euro 5	n/a ^a	
Bharat Stage VI	Euro 6	2020.04	Nationwide [3827]

* National Capital Region (Delhi)
 † Mumbai, Kolkata, Chennai, Bangalore, Hyderabad, Secunderabad, Ahmedabad, Pune, Surat, Kanpur and Agra
 ‡ Above cities plus Solapur and Lucknow. The program was later expanded with the aim of including 50 additional cities by March 2015
^a Initially proposed in 2015.11 [3297][3298] but removed from a 2016.02 proposal [3349] and final BS VI regulation [3827]

4

Table 2 Emission Standards for a Diesel Car (GVW ≤ 2500 kg)

g/km						
Year	Reference	CO	HC	HC+NO _x	NO _x	PM
1992	–	17.3–32.6	2.7–3.7	–	–	–
1996	–	5.0–9.0	–	2.0–4.0	–	–
2000	Euro 1	2.72–6.90	–	0.97–1.70	0.14–0.25	–
2005†	Euro 2	1.0–1.5	–	0.7–1.2	0.08–0.17	–
2010†	Euro III	0.64	–	0.56	0.50	0.05
2010‡	Euro 4	0.50	–	0.30	0.25	0.025

† earlier introduction in selected regions, see Table 1
 ‡ only in selected regions, see Table 1